

ENCLOSED

- Application & Contract For Space
Prospectus (Rules & Regulations)
Preliminary Exhibition Floor Plan

RULES & REGULATIONS

Rules & Regulations will be enforced to protect the rights of all exhibitors, the safety of attendees and the overall welfare of the Show. Please review the rules carefully before applying for space. All rules will be strictly enforced and we urge you to not create hardships for you or your booth personnel by failing to learn and comply with the Rules & Regulations.

HBA OF GREENVILLE MEMBERS ENJOY DISCOUNTED SPACE RENTAL RATES

Rates Per 10 x 10 Before August 15:

HBA of Greenville Members: \$500.00

Corner Booths: \$600.00

Non-Members: \$650.00

Corner Booths: \$775.00

DEDUCT: 5% For More Than One Booth

ADD: \$100 Per Booth After August 15, 2010

If you wish to join the Home Builders Association of Greenville, please contact our office for further details.

PLEASE VISIT OUR WEBSITE, WWW.HBAOFGREENVILLE.COM,

or telephone our office at 864.254.0135 if you have any questions or require additional information.

We will provide a direct link from the Exhibitor List on our website to your website, as a value-added service for exhibiting with us, and at no additional charge!

PREVIOUS SHOW (2009 FALL) STATISTICS

- Total No. of Exhibitors 126
Net Square Footage Occupied By Exhibits..... 22,100
Total Attendance..... 3,935

THE HOMEBUILDERS ASSOCIATION OF GREENVILLE PROUDLY PRESENTS

THE 2ND ANNUAL FALL SOUTHERN HOME & GARDEN SHOW

Following the Inaugural show in 2009 the Home Builders Association of Greenville is proud to present the 2nd Annual Fall Edition. The Fall Southern Home & Garden Show will be held October 15 - 17, 2010 at the Carolina First Center in Greenville, South Carolina. The three-day event will serve as a smaller version of our Spring Southern Home & Garden Show, offering a seasonal opportunity for exhibitors to reach consumers planning fall fix-ups, remodeling projects, and special seasonal decor.

We extend to you a special invitation to exhibit with us during this exciting event. Enclosed please find an Application & Contract For Space, Prospectus (Rules & Regulations) and Preliminary Exhibition Floor Plan.

EXHIBIT SPACE RATES HAVE BEEN REDUCED FOR THE 2010 FALL SHOW

In an effort to assist our exhibitors during this tough economic time and to increase your company's presence at both the Fall and Spring Shows, exhibit space rental rates have been reduced for the 2010 Fall Southern Home & Garden Show. We hope you will take advantage of these special rates and the opportunity to promote your products face-to-face to consumers.

EXHIBIT SPACE IS ASSIGNED ON A FIRST-COME, FIRST-SERVED BASIS

Applications & Contracts For Space in the 2nd Annual Fall Southern Home & Garden Show are now being accepted.

Assignments of space to exhibitors in the 2009 Fall Show began June 15, 2010. Exhibit space will now be assigned on a first-come, first-

served basis. We urge you to act promptly and complete the enclosed Application & Contract For Space and forward the form with your deposit by return mail or fax and

no later than July 15, 2010. Exhibitors applying for space by this deadline will receive DOUBLE the number of Complimentary Admission Tickets

as our Thank You for your early commitment to exhibit with us.

Fifty percent (50%) of your total space rental amount is due with the Application & Contract For Space. The deposit must accompany the Application & Contract For Space for an assignment to be processed. Application will not be processed and space assignment will not be made until deposit is received.

Second and final payments for space are due from all exhibitors on or before September 15, 2010.

Space rental rates increase \$100.00 per booth after August 15, 2010.

APPLY FOR SPACE NOW

COMPLETE AND FORWARD THE APPLICATION & CONTRACT FOR SPACE WITH YOUR DEPOSIT BY RETURN MAIL, FAX OR EMAIL TODAY.



BOOTH DESCRIPTIONS & DISPLAY HEIGHT RESTRICTIONS

IN-LINE BOOTH OR LINEAR BOOTH

In-Line or Linear Booths have only one side exposed to an aisle and are arranged in a series along a straight line.

Display materials should be arranged in such a manner so as not to obstruct sight lines of neighboring exhibitors. The maximum height of 8-Ft. is allowed only in the rear half of the booth space, including signs, with a 4-Ft. height restriction imposed on all materials in the remaining space forward to the aisle.

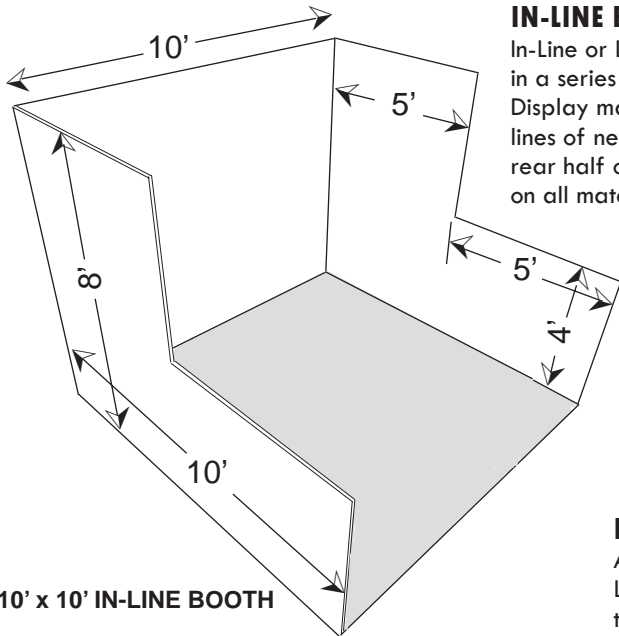

10' x 10' IN-LINE BOOTH

CORNER BOOTH

A Corner Booth is a Linear Booth exposed to aisles on two sides. All height restrictions for Linear Booths apply to Corner Booths.

PERIMETER BOOTH

A Perimeter Booth is a Linear Booth that backs to an outside wall of the exhibit facility rather than to another exhibit. Display material within the first 2-Ft. from the aisle may not exceed 8-Ft. in height, and in the remaining exhibit space no higher than 15-Ft.

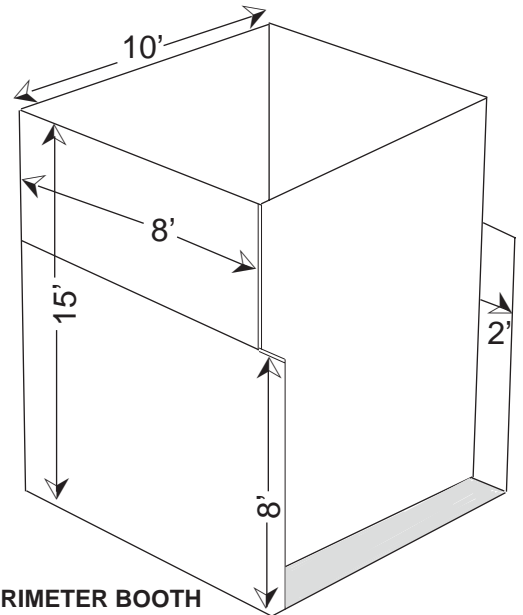

PERIMETER BOOTH

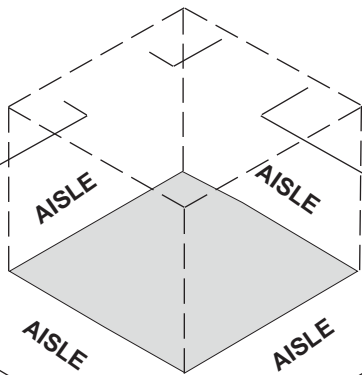

ISLAND BOOTH

ISLAND BOOTH

An Island Booth is four or more standard booths and is exposed to aisles on all four sides.

Display material is restricted to a height of 15-Ft.

PENINSULA BOOTH

A Peninsula Booth is exposed to aisles on three sides.

The backwall is restricted to 4-Ft. high within 5-Ft. of each aisle, permitting adequate line of sight for the adjoining Linear Booths. Eight feet (8') is the maximum height allowance, including signage, for the center portion of the backwall.

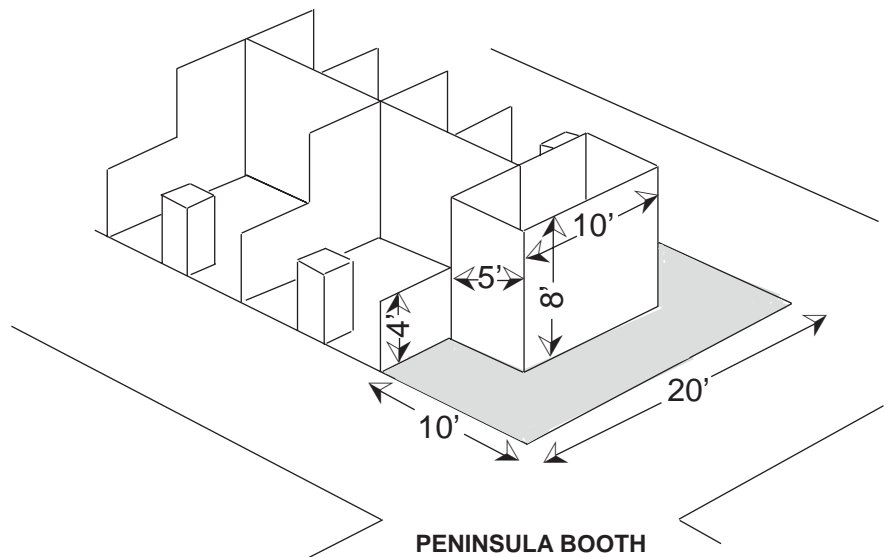

PENINSULA BOOTH